WISE OWL

PAINT



Wise Owl Paint Turbine Sprayer, Metal INSTRUCTION MANUAL



DO NOT USE EQUIPMENT BEFORE READING THIS MANUAL

This manual contains important warnings and instructions.
Please read these instructions carefully and keep for your reference.
©2020 Apollo Sprayers International, Inc.

Safety

Read all instructions and safety precautions before operating the unit.



Indicates a hazardous situation, which, if not avoided, will result in death or serious injury.



Indicates a hazardous situation, which, if not avoided, could result in death or serious injury.



Indicates a hazardous situation, which, if not avoided, could result in minor or moderate injury.

NOTICE

Indicates a situation that could result in damage to the equipment or other property.



Risk of fire or explosion! Solvent and paint fumes can explode or ignite, causing severe injury and property damage.



Paints and solvents containing HALOGENATED HYDROCARBONS can react explosively with aluminum. Always check the product's label before using these materials in the unit.

Hazardous vapors: Paint, solvents, insecticides and other materials may be harmful if inhaled, causing severe nausea, fainting or poisoning.

Make sure the room is well ventilated. Avoid all ignition sources, such as static electricity, sparks, open flames, hot objects, sparks from connecting and disconnecting power cords, and working light switches.



Follow the material and solvent manufacturers' safety precautions and warnings. Do not use liquids with flash points less than 100° F (38° C).

Static electricity can be produced by HVLP spraying. Make sure any electrically conductive object being sprayed is grounded to prevent static sparking. The sprayer is grounded to prevent static sparking. The sprayer is grounded through the electrical cord.

Use a respirator or mask whenever there is a chance that vapors may be inhaled. Read all instructions with the mask to ensure that the mask will provide the necessary protection against the inhalation of harmful vapors.



Do not carry the turbine while spraying.

Keep the turbine at the maximum distance from the spraying area.

NOTICE

- Tipping the spray gun causes the spray gun to clog. Dried spray material also clogs the pressure delivery tube and fittings. The spray gun does not function when clogging occurs.
- When not in use, be sure to disconnect the hose and place the spray gun into the Handi-Hold™ Docking Station on the turbine to avoid tipping.

⚠ DANGER

Improper installation of the ground plug can result in the risk of electrical shock. If repair or replacement of the plug or cord is necessary, do not connect the ground wire to either flat blade terminal. The wire with green insulation (with or without a yellow stripe) is the grounding wire.

1. For any question regarding proper installation of the ground plug, consult a qualified (licensed or certified) electrician.
2. Do not modify the plug provided. If the plug does not fit the outlet, have the proper outlet installed by a qualified electrician.
3. This product is for use on a nominal 110-volt circuit and has a grounding plug that looks like the plug in Figure 2. Make sure that the product is connected to an outlet having the same configuration as the plug. Do not use adapters with this product.



4. If an extension cord is required, use only a three-wire extension cord that has the same configuration as the unit cord, including the (round) ground terminal. Make sure that the extension cord is plugged into a properly grounded receptacle.

5. Use only a three-wire extension cord with a 3-slot receptacle similar to the plug on the turbine. Make sure your extension cord is in good condition. When using an extension cord, be sure to select one that will carry a heavy enough current for the turbine motor. An undersized cord will cause a drop in the line voltage resulting in loss of power and overheating. If in doubt use the next heavier gauge. The smaller the gauge number, the heavier the wire thickness. Please use the chart below as a guide to selecting the proper size extension cord.

25' cord (7.62m).....	10, 12, or 14 Gauge
50' cord (15.24m).....	10 or 12 Gauge
100' cord (30.48m).....	10 Gauge

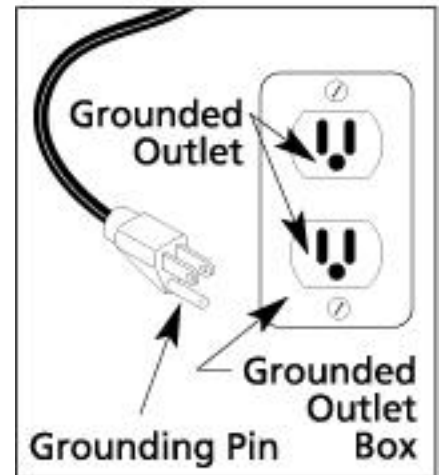

Figure 2

⚠ CAUTION

This product must be properly grounded. In the event of an electrical short circuit, grounding reduces the risk of electrical shock by providing an alternate path for the electrical current.

This product is equipped with a cord that has a ground wire and an appropriate ground plug. Plug the unit into an outlet that is properly installed and grounded in accordance with local codes and ordinances.

Safety Note: Users in countries in continental Europe and Australia and anywhere that offers a two-pronged plug must be aware that this configuration does not provide grounding.

CONGRATULATIONS! You have just purchased the finest HVLP Spray system available. You are about to enjoy the great benefits of **TrueHVLP™** spraying, flawless applications, and a very short learning curve. Our designs are the result of many years of experience in manufacturing **TrueHVLP™** Turbine spray systems and spray guns.

Whether you are new to spraying, you have sprayed before, or are just new to HVLP spraying; there are some basic spraying guidelines that will help you to achieve the best results and optimum success from your new equipment. Reading this information carefully and following these simple steps will ensure that you get the best performance and results from your new spray system.

CONTENTS

Check the contents of your box. The following are included:

1. Turbine Spray unit
2. Spray Gun
3. Air hose
4. Instruction Manual
5. Electric Cord

HOW YOUR TrueHVLP™ SPRAY SYSTEM WORKS

Your TrueHVLP™ Spray System has three components:

1. Turbine unit
2. Spray Gun
3. Air Hose



The Turbine unit, when connected to the correct electrical power supply and with the on/off switch in the “on” position provides a continuous source of clean, warm, dry, low- pressure turbo air. There is never a need for any inline filters or dryers. The air hose connects the Turbine unit to the spray gun. Air flows through the hose to the nozzle of the specially designed spray gun. Atomization of the material/coating is achieved when the high CFM of airflow mixes with the stream of fluid passing through the specialty designed nozzle. This low-pressure atomization principle achieves minimum misting (overspray) to the spray environment and maximum solution transfer efficiency to the substrate because of less “Bounce Back”. The Turbine has one air hose outlet on the side of the unit and is designed to run one spray gun.

Bounce Back Comparisons

Conventional Spray Systems

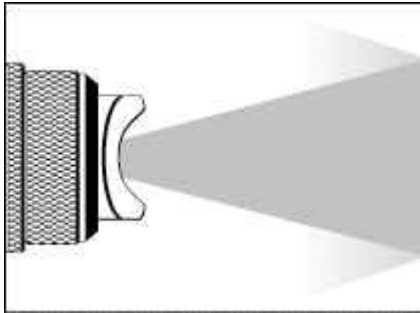

Conventional spray systems:

- 12-20 PSI @ 8 CFM
- 30-50% transfer efficiency
- Excessive, costly Solution waste
- Unhealthy for operator and harmful to the environment

TrueHVLP™ Spray Systems

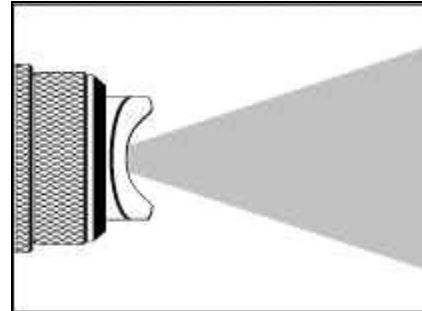

TrueHVLP™ Spray Systems:

- 5.5 PSI @ 65 CFM
- Up to 90% transfer efficiency
- Substantial Solution savings
- Cleaner and safer for both operator and environment

Your spray gun offers you many options. You can turn the air cap (#8) to three positions. One will produce a horizontal pattern for spraying across, another will produce a vertical pattern for spraying up and down, and the third will produce a round pattern to spray small or narrow pieces.

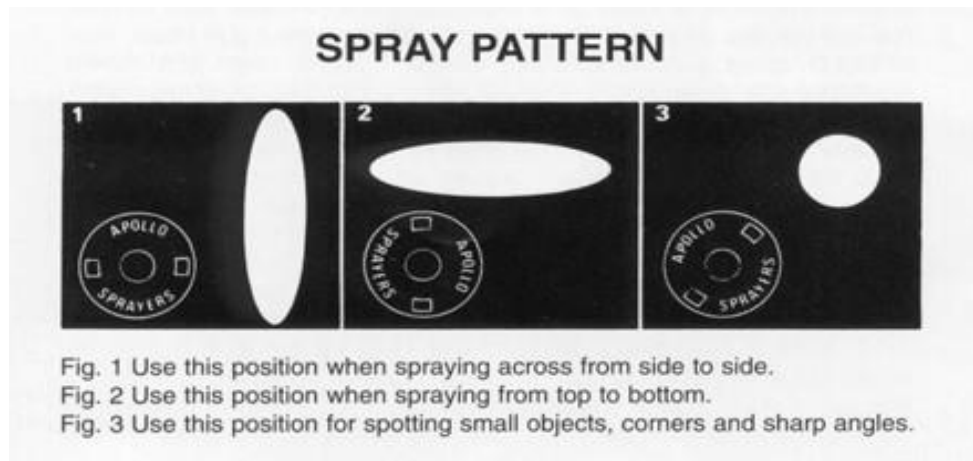

PREPARING TO USE YOUR SPRAY SYSTEM

Connect the air hose to the turbine by screwing the female end of the air hose to the male thread on the side of turbine.



If you have just finished spraying, the metal coupler at the turbine end may be hot.



Connect the other end of the hose to the spray gun, by pulling back on the spring-loaded ring and inserting it over the male connector on the top of the spray gun.

Plug the electric cord into a correctly grounded electrical outlet. Be sure the electric current is the correct voltage. If you need to use an extension cord, refer to page 3 for the proper thickness.

Select a safe, well-ventilated area where you will spray your project. Locate your Turbine unit as far away from the area where you will be directly spraying, so that the paint doesn't get sucked into the filters.



NOTICE

Do not cover or enclose the turbine. It is important to draw cool/ambient air through the unit for optimum performance. Avoid placing the turbine in a warm environment or in direct sunlight. Do not spray in ambient temperatures above 90 degrees Fahrenheit. If you want to be able to spray in hotter temperatures we recommend placing a fan in front of your turbine to help it pull in cool air.

FAMILIARIZING YOURSELF WITH YOUR SPRAY GUN

Familiarize yourself with the controls on the spray gun. There are two principal controls: The rotating air cap (#2); the material flow adjusting screw (#16). To rotate the air cap loosen the air cap ring slightly to allow air cap to rotate into each position, Horizontal, Vertical and Diagonal. The horizontal position will give you a vertical fan pattern. The vertical position will give you a horizontal fan pattern and the Diagonal position will give you a round, dot pattern.

Next, turn the material flow Adjusting screw (#16) anti- or counter-clockwise to open or release more fluid, clockwise to reduce fluid flow. NOTE: If you are using the round fan pattern it is usually necessary to reduce the amount of fluid.

PREPARING TO SPRAY

You should now be ready to spray your project. Good quality results with your TrueHVLP™ Spray System are a combination of careful preparation of your substrate, a proper spraying environment, a basic knowledge of the material/coating you will be using and how these materials work with your Turbine.

USING YOUR SPRAY GUN

Your Spray Gun is certified TrueHVLP™. This means your spray gun uses no more than 10 PSI. All passages and air ports are much larger than a conventional spray gun. If one of these air passages becomes blocked, or build-up of material starts to occur, your spray pattern will become distorted, therefore, always keep your spray gun clean. The spray gun comes fitted with a 1.0 mm nozzle and needle. This size will effectively spray most wood coatings. Using this size of nozzle and needle you can achieve a 1/4" line up to a 10" fan pattern, simply by rotating the air cap to the desired fan type, opening the material flow screw counter-clockwise and moving the spray gun closer or further away from your work piece. A little practice will enable you to master this technique in no time flat!

PRACTICE IS VERY IMPORTANT!

Here are some suggestions to practice with your spray gun before you put paint in it. Remove the cup from your spray gun. Fill it approximately halfway with some water. Reattach the cup to the body of the spray gun to create a good seal. Attach the spray gun to the air hose and the other end of the air hose to the turbine. Turn the turbine unit on. You will notice that the air is constantly flowing out of the air cap. This is normal. When you pull the trigger, you will release the paint into the air stream. Position the air cap in the horizontal or vertical position, turn the material flow screw clockwise until closed. Make a mark on the material flow screw at 12:00 (Noon), and then adjust the material flow screw to 8:00; this will give you a good starting point. Point the spray gun away from yourself (and anyone else) and pull the trigger all the way back. You should see a "V" shaped mist (or triangle) called a fan pattern come from the fluid nozzle. Now, with the trigger depressed, if you turn the material flow screw, clockwise (closing) making very small adjustments at a time, you will notice that the fan pattern is beginning to get smaller. Now, reverse this and notice the pattern will get larger. Take a large piece of cardboard and direct the pattern at the surface, hold the spray gun approximately 6"-8" from the surface. Pull the trigger, observe the outline and size of the pattern. Now, turn the material flow screw clockwise (closing). Move the spray gun an inch or two closer to the surface. Pull the trigger. Notice the pattern has become smaller. You can continue reducing the material flow and move the spray gun even closer to the surface and the pattern will continue to get smaller and smaller. Play with varying the material flow and the distance of the spray gun from the work surface. Notice the change in pattern size.

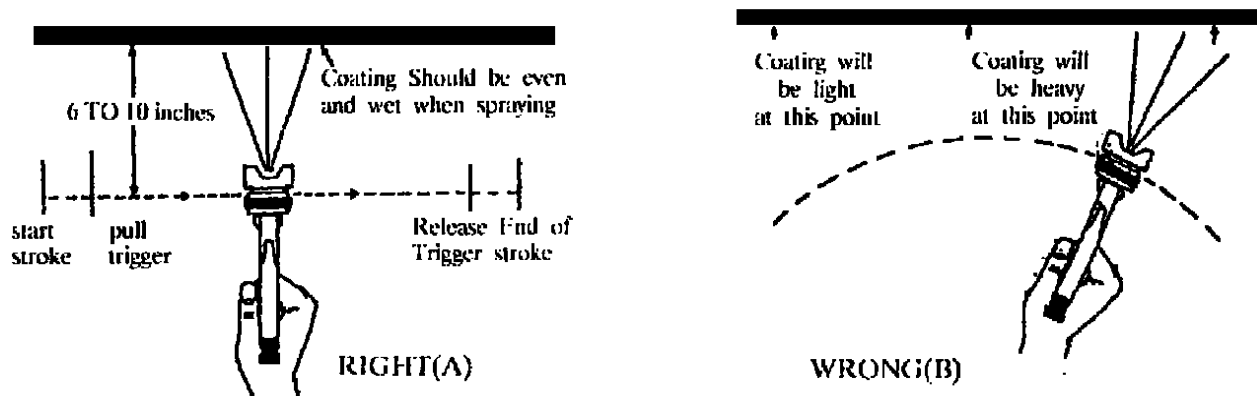

CAUTION

Even when the turbine unit is off, pressure will remain in the spray cup. If you pull the trigger back, a stream of fluid will flow. To prevent accidents, turn material flow screw clockwise until it is completely closed. The trigger is now locked in the closed position. To release the pressure in the cup prior to removing the cup, simply twist the cap on the cup lid counter clockwise until you hear the air come out. When done, tighten the cap back up.

TURBINE MAINTENANCE & CLEANING

The turbine unit needs virtually no maintenance. The motor has sealed bearings that are pre-lubricated. No service is necessary. Periodically, the turbine's air filters should be examined. Clean filters are critical to good performance and equipment longevity. Your turbine has 2 replaceable filters. Remove the two hex-head securing nuts in order to remove the filters for cleaning or replacement. Periodically wash and blow excess dust and dirt with water and an air compressor. Dirty filters will reduce the air being drawn through the motor, causing the unit to run abnormally hot, diminish spray performance and reduce the life of the motor. Clean and/or replace. Use the maintenance record sheet to keep track of your equipment use.

Turbine Recommended Maintenance: Clean and/or change pre-filters and/or cartridge filters every 50 hours or when necessary.

SPRAY GUN MAINTENANCE AND CLEANING

You do not need to clean your spray gun every time you stop spraying. Either put the spray gun on the gun holder located on the turbine or hang it by the hook so that it doesn't tip over. You should always clean your spray gun at the end of a work session or at the end of the day. It is not a good idea to leave material in the spray gun overnight. Also, pay careful attention in keeping the threads on the main gun body clean. Dried material on the threads can cause the parts to bind and lock up.

1. When you have finished spraying, pour the remainder of your material out of the spray gun cup. Pour in a small amount cleaning fluid or warm water if appropriate. Use a cleaner that is compatible with the coating you just sprayed. (Water if product is water-soluble). Shake the spray gun gently. Wait about 10 seconds and spray out the cleaner in the cup. To protect the environment, you can spray the cleaner into a container or into a large rag that you have wadded into a large ball. Repeat this process until the cleaning fluid is free from color and debris.
2. If necessary, remove the fluid nozzle (#6) and fluid nozzle gasket (#7). A standard wrench will fit the flanges on the fluid tip. Be careful not to lose or misplace the fluid nozzle gasket. Rinse with appropriate cleaner.
3. To remove the needle, turn the material flow adjusting screw (#16) all the way counter (anti) clockwise until it comes out of the spray gun. Carefully remove the needle spring (#14). Pull the trigger and then the needle assembly through the back of the spray gun. Rinse and wipe clean.
4. Wipe all exposed areas clean.
5. Although they might not need attention every time you spray, you should be aware of two additional important parts on your spray gun. One is the cup gasket (#29) and the gland seal (#20).
 - a The cup gasket ensures that the cup is properly sealed to the spray gun body, the cup is properly pressurized and no fluid leaks from the spray gun cup. Replace as necessary. To prolong the life of the gasket always store the cup a little loose on the spray gun.
 - b The gland seal compresses around the fluid needle assembly to prevent fluid from leaking around the needle. This is adjusted by tightening (or loosening) the gland nut (#21). Be sure that this nut is not too tight so that it does not allow free movement of the needle assembly. Be sure that this nut is not too loose as to permit fluid to leak around the needle. Normally, this is preset at the factory and should need no adjustment. Replace the gland seal when it becomes impossible to prevent leaking.
6. Store your spray gun for the next use.

Spray Gun Recommended Maintenance: Check: Cup gasket, nozzle gasket, gland seal, air cap holes, nozzle/needle assembly every 20 hours or when necessary. Clean or replace parts as needed.

TROUBLESHOOTING

1. **Material cup full, turbine air is supplied to the spray gun. Trigger is pulled and no material comes out** – Reason: Cup not pressurizing.
 - A. Check Non-return valve installed correctly.
 - B. (Cone side facing toward cup)

- C. Check Non-return valve. Clean or replace as necessary.
- D. Check Air feed connector has a blockage. Check and clean as necessary.
- E. Make sure cup is tight.
- F. Make sure the cup top gasket is not damaged or worn out.
- G. Check the nozzle for a blockage of dried paint.

2. There is paint leaking from the gland nut.

- A. Tighten gland nut slightly and test.
- B. Replace the gland seal as needed.

3. If you think that you are getting too much “overspray”.

- A. Tighten the gland nut slightly and test.
- B. Try moving the spray gun closer to the work or closing down the fluid flow more. Remember your spray system is designed to be used no more than 6”-8” away from your substrate. Make sure you are no further than that away when spraying and you should minimize your overspray.

Please feel free to call the factory if you have any additional question concerning cleaning or operation of your spray system. The factory’s toll-free number is 1-888-900-HVLP (4857). Our hours of operation are from 8-4pm Monday-Friday Pacific Time.

ApolloSpray E5011 Q/R Cup Gun

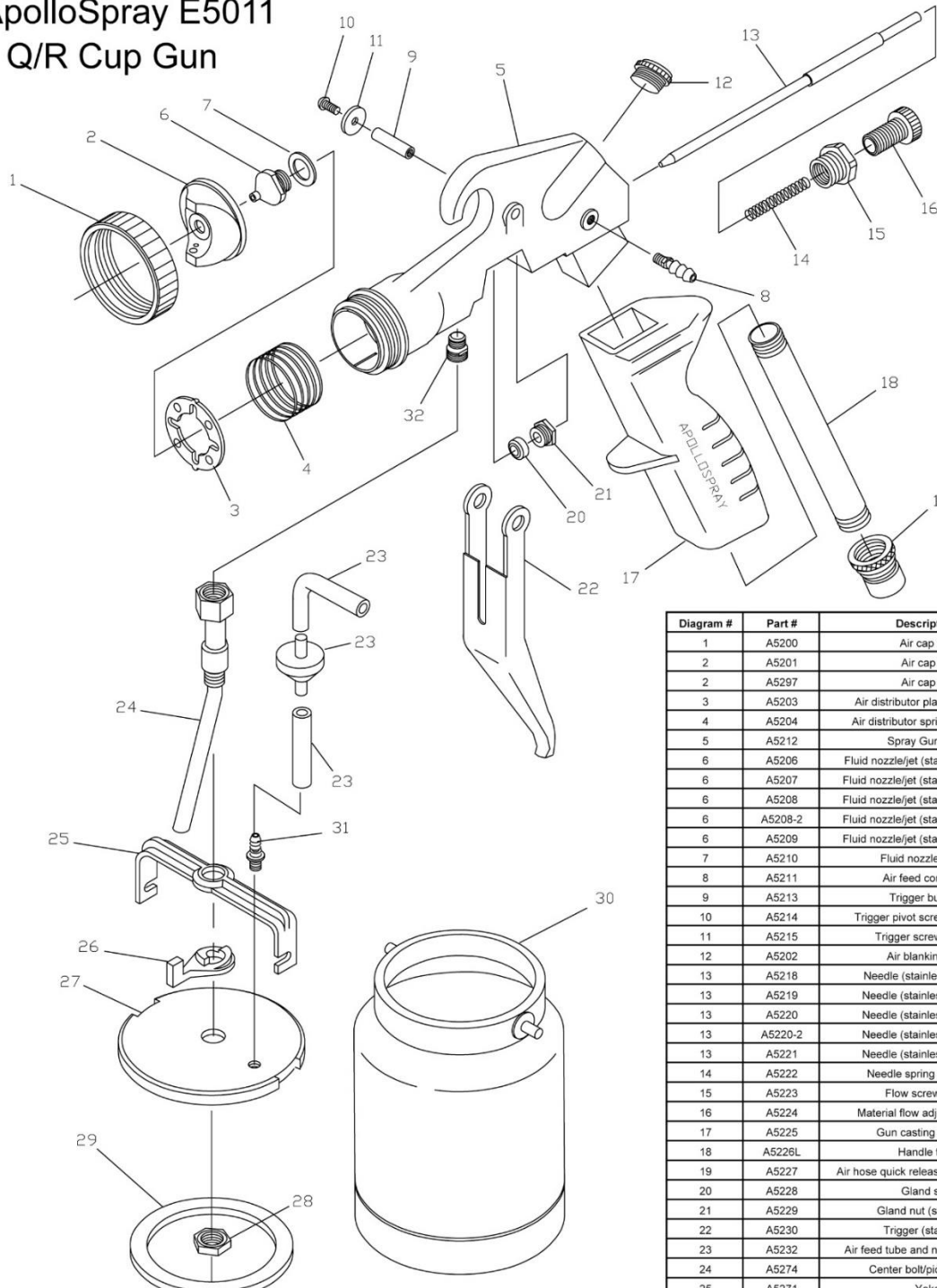

Parts List & Diagram 760-727-8300

Diagram #	Part #	Description
1	A5200	Air cap ring
2	A5201	Air cap # 1
2	A5297	Air cap # 2
3	A5203	Air distributor plate (stainless)
4	A5204	Air distributor spring (stainless)
5	A5212	Spray Gun Body
6	A5206	Fluid nozzle/jet (stainless) .75MM
6	A5207	Fluid nozzle/jet (stainless) 1.00MM
6	A5208	Fluid nozzle/jet (stainless) 1.50MM
6	A5208-2	Fluid nozzle/jet (stainless) 2.00MM
6	A5209	Fluid nozzle/jet (stainless) 2.50MM
7	A5210	Fluid nozzle gasket
8	A5211	Air feed connector
9	A5213	Trigger bushing
10	A5214	Trigger pivot screw (stainless)
11	A5215	Trigger screw washer
12	A5202	Air blanking plug
13	A5218	Needle (stainless) .75MM
13	A5219	Needle (stainless) 1.00MM
13	A5220	Needle (stainless) 1.50MM
13	A5220-2	Needle (stainless) 2.00MM
13	A5221	Needle (stainless) 2.50MM
14	A5222	Needle spring (stainless)
15	A5223	Flow screw insert
16	A5224	Material flow adjusting screw
17	A5225	Gun casting (handle)
18	A5226L	Handle tube
19	A5227	Air hose quick release coupler (male)
20	A5228	Gland seal
21	A5229	Gland nut (stainless)
22	A5230	Trigger (stainless)
23	A5232	Air feed tube and non-return valve
24	A5274	Center bolt/pick-up tube
25	A5271	Yoke
26	A5278	Lever
27	A5270	Cup top casting
28	A5272	Cup top lock nut
29	A5280	Cup top gasket (White poly)
30	A5275	Quick release cup
31	A5324	Air stem Q/R cup
32	A5254	Fluid connector 3/8" (stainless)

Warranty

Two Year Warranty

The machine and Equipment are WARRANTED by APOLLO SPRAYERS INTERNATIONAL, INC. for a total period of TWO YEARS from the ORIGINAL date of purchase by the ORIGINAL PURCHASER. Proof of purchase to be included and all SHIPPING CHARGES to be pre-paid.

APOLLO SPRAYERS INTERNATIONAL INC., upon examination of the machine/equipment will replace or repair at their discretion any defects in material or workmanship.

This WARRANTY does NOT include: misuse, damage, neglect, alterations, disassembled equipment or modifications, lack of maintenance, cleaning, water damage to electrical parts, INCORRECT VOLTAGE CONNECTION.

This Warranty is in lieu of all other express warranties, any WARRANTY implied by law, including but not limited to, implied Warranties of merchantability or fitness, is excluded to the maximum extent permitted by law and, if not excludable, is limited to the duration of the express Warranty.

No representative or person is authorized to extend this Warranty or to create for APOLLO SPRAYERS INTERNATIONAL, INC. any other liability in connection with the sale of any APOLLO SPRAYERS product. APOLLO SPRAYERS INTERNATIONAL, INC. shall not be liable for any consequential, incidental or special damages of any kind directly or indirectly resulting from breach of any express or implied warranty.

Some states do allow the exclusion or limitation of incidental or consequential damages or limitations on the length of any Warranty so that the above limitations and exclusions may not apply to you: however, to the maximum extent permitted under applicable law, the only rights and remedies shall be to obtain a replacement for any defective product.

This Warranty gives you specific legal rights and you may also have other rights which vary from State to State.

Apollo Sprayers International, Inc.
1030 Joshua Way, Vista, CA 92081
Customer Service: (760) 727-6226
Fax: (760) 727-9325
Toll Free Sales: (888) 900-HVLP (4857)
www.hvlp.com

 **WARNING:** This product can expose you to chemicals including Chromium, which is known to the State of California to cause cancer and birth defects or other reproductive harm. For more information go to www.P65Warnings.ca.gov.